

CCA Kits

Data logger/gateway, Tigo Access Point (TAP), power supply, and outdoor enclosure options

The Cloud Connect Advanced (CCA) is a compact, powerful data logging and communications gateway that powers the monitoring and safety capabilities of Tigo TS4 module level power electronics (MLPE). CCA Kit options provide all the components needed for communicating between inverters, TAPs, TS4s, and the Tigo Energy Intelligence platform.



CCA

- Collects data from up to 900 TS4s via up to seven TAPs
- Connects to wired and wireless networks
- Includes a multifunction LED status indicator
- Configured and commissioned with the Tigo Energy Intelligence (EI) app
- Monitors 3rd-party devices via Modbus

TAP

- Collects data from up to 300 TS4s
- Wireless mesh communication
- Scalable architecture
- Mounts easily on module frames without tools

Power Supplies/Outdoor Enclosure

- Outlet and DIN rail power-supply options
- Compact, DIN rail design
- IP67, NEMA 4 rated enclosure

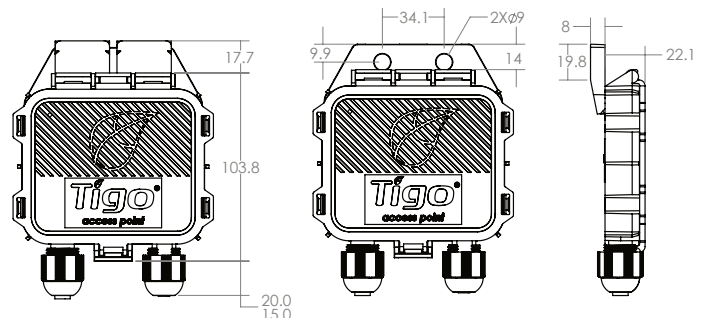
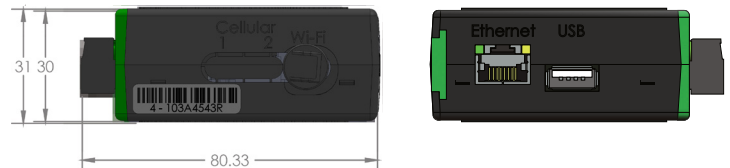
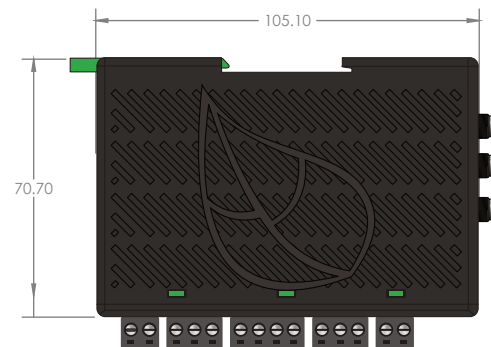
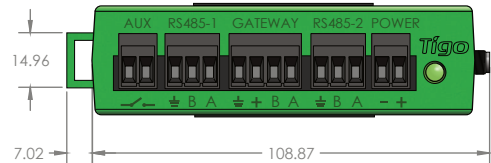

Specifications

CCA

Operating temperature range	-20 – 85°C (-4 – 185°F)
Maximum altitude	3000m (9840ft)
Cooling	Natural convection
Input voltage	10 – 25V _{DC}
Power consumption (up to 7 TAPs)	3 – 10W
Dimensions (W/D/H)	31 x 115.5 x 71.5mm (1.2 x 4.5 x 2.8in)
Weight	126g (.28lbs)

TAP

Operating temperature range	-20 – 85°C (-4 – 185°F)
Environmental rating	IP68/NEMA 4X

Power Supplies/Outdoor Enclosure

Operating temperature range	-20 – 70°C (-4 – 185°F)
Input voltage	50/60Hz, 100 – 240V _{AC}
Power consumption (up to 7 TAPs)	3 – 15 W
Dimensions (W/D/H)	203 x 115 x 278.4mm (8 x 4.5 x 11in)
Weight (w/CCA and power supply)	1.1kg (2.4lbs)
Environmental rating	IP67/NEMA 4X
Cooling	Natural convection

Ordering Information

344-00000-52	CCA Kit with TAP, DIN rail power supply
346-00000-00	CCA standalone
348-00000-52	CCA Kit with TAP, DIN rail power supply, outdoor enclosure

Additional Resources

