

BOS-A



Product advantages

- ❑ Supports larger current output, up to 160A
- ❑ A single system has a higher battery capacity and can be compatible with inverters with higher power
- ❑ Dual electrode disconnection design for battery system
- ❑ The battery system has dual power output plugins, and the single power plugin can support 100A. It can be connected to two battery DC interfaces of the inverter separately
- ❑ A concise data display interface to assist in faster initial installation and debugging
- ❑ Supports mobile Bluetooth APP access, convenient connection, and allows for viewing more detailed system data

Model	BOS-A		
-------	-------	--	--

Main Parameter			
Cell Chemistry	LiFePO4		
Module Energy (kWh)	7.68		
Module Nominal Voltage (V)	38.4		
Module Capacity (Ah)	200		
Module Dimension (W/D/H,mm)	601.5*520*135		
Module Weight Approximate (kg)	70		
Battery Module Qty In Series (Optional)	7	13	21
System Nominal Voltage (V)	268.8	499.2	806.4
System Operating Voltage (V)	235.2~306.6	436.8~569.4	705.6~919.8
System Energy (kWh)	53.76	99.84	161.28
System Usable Energy (kWh) ¹	48.38	89.85	145.15
Charge/Discharge ² Current (A)	Recommend	100	
	Max	160	
Working Temperature (°C)	Charge: 0~55/Discharge: -20~55		
Status Indicator	Yellow: Battery High Voltage Power On Red: Battery System Alarm		
Communication Port	CAN2.0		
Humidity	5%~85%RH		
Altitude	≤3000m		
IP Rating of Enclosure	IP20		
Dimension (W/D/H,mm)	1900x610x610	2350x610x610	1900x610x610
Weight Approximate (kg)	558	985	1586
Installation Location	Rack Mounting		
Storage Temperature (°C)	0~35		
Recommend Depth of Discharge	90%		
Cycle Life	25±2°C,0.5C/0.5C, EOL70%≥6000		
Warranty ³	10 years		
Certification	CE/IEC62619 /IEC62040/UN38.3/VDE-2510		

1. DC Usable Energy, test conditions: 90% DOD, 0.3C charge & discharge at 25°C. System usable energy may vary due to system configuration parameters.

2. The current is affected by temperature and SOC.

3. The warranty is due whichever reached first of warranty period or life cycle power.

System Backup solution

Backup power duration plan	2 hours		4 hours	
	50KW	80KW	50KW	80KW
Hybrid inverter power	50KW	80KW	50KW	80KW
Battery model	BOS-A100	BOS-A160	BOS-A100	BOS-A160
Number of batteries	1 pcs	1 pcs	2 pcs	2 pcs

50KW/100KWh

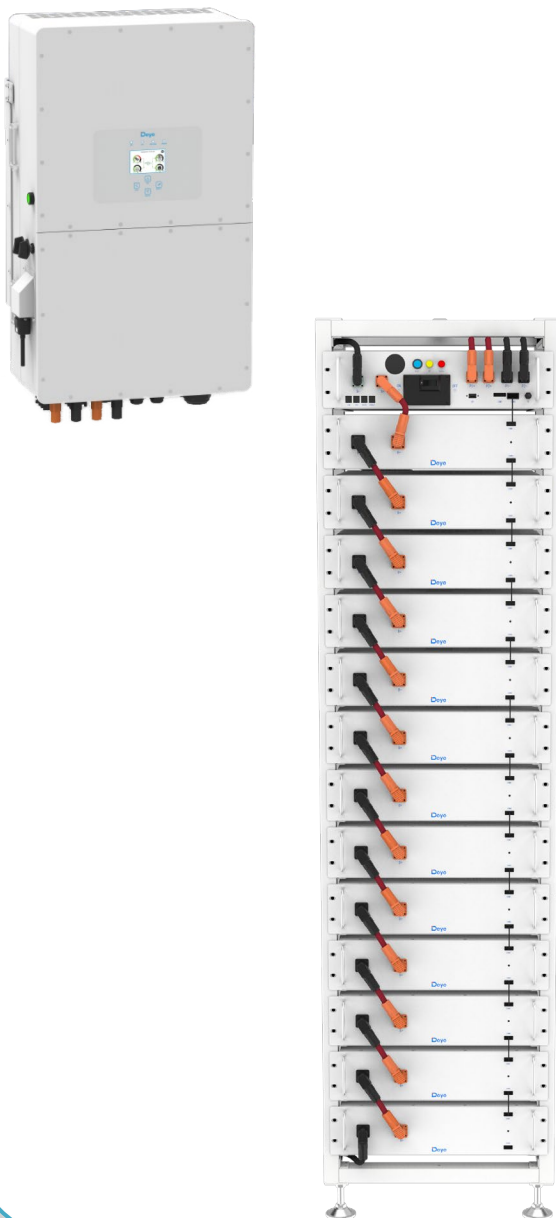

80KW/160KWh

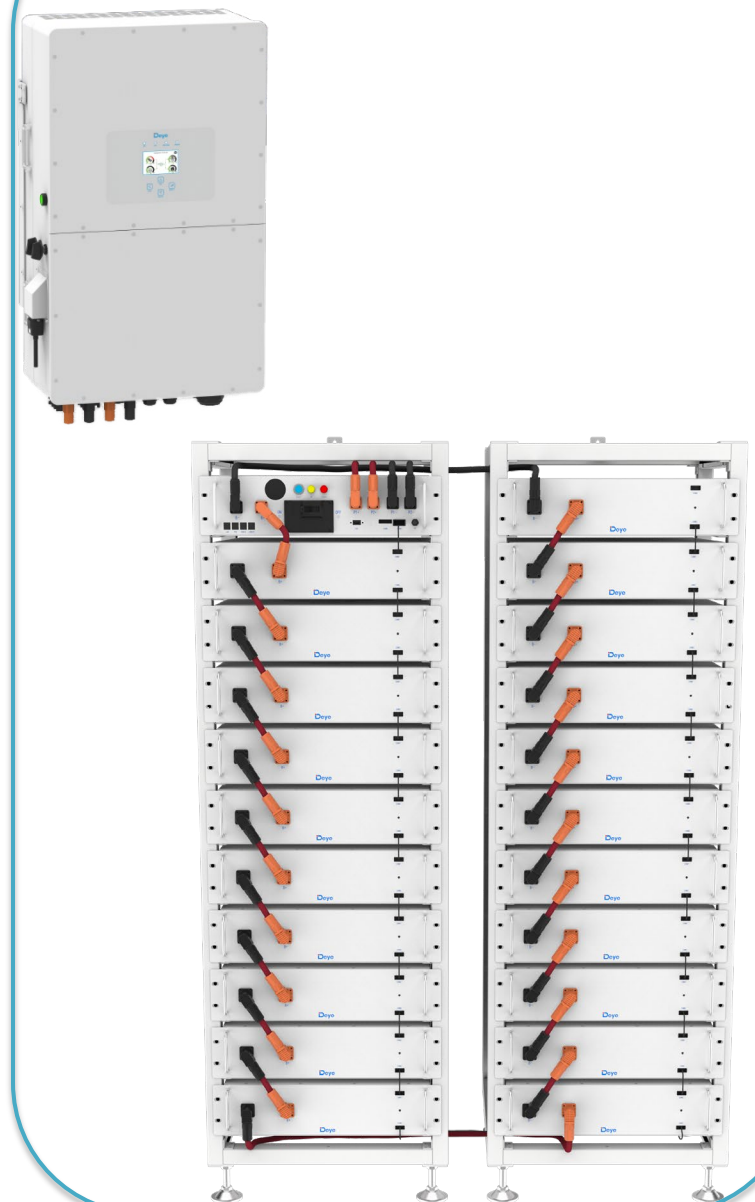

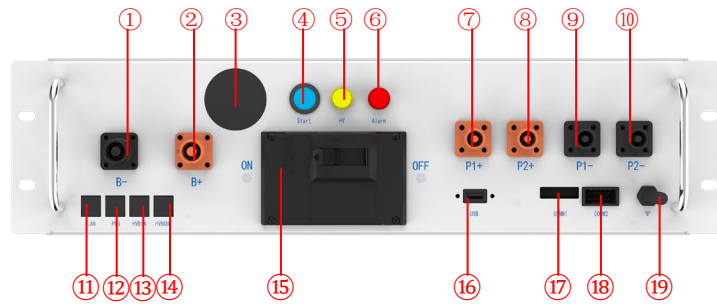

①B-	Connection position of the common negative pole of the battery
②B+	Connection position of the common positive pole of the battery
③LED panel	Displays SOC and fault codes
④START	A start switch of 12VDC power inside the high-voltage control box
⑤HV light indicator	High-voltage hazard indicator
⑥ALRM light indicator	Battery system fault alarm indicator
⑦PCS1+	Connection position of PCS1 positive pole
⑧PCS2+	Connection position of PCS2 positive pole
⑨PCS1-	Connection position of PCS1 negative pole
⑩PCS2-	Connection position of PCS2 negative pole
⑪LAN	Ethernet communication interface
⑫PCS COM	Communication interface with charging and discharging equipment
⑬IN COM	Connection position with previous GE-F-PDU communication input
⑭OUT COM	Connection position with next GE-F-PDU communication output
⑮Air switch	Used to manually control the connection between the battery rack and external devices
⑯USB	BMS upgrade interface and storage expansion interface
⑰COMM1	12VCD power supply port
⑱COMM2	Communicative connection with the first battery module; and providing 12VDC power for the first battery module.
⑲WiFi/ Bluetooth capture stick	Collect WiFi or Bluetooth information

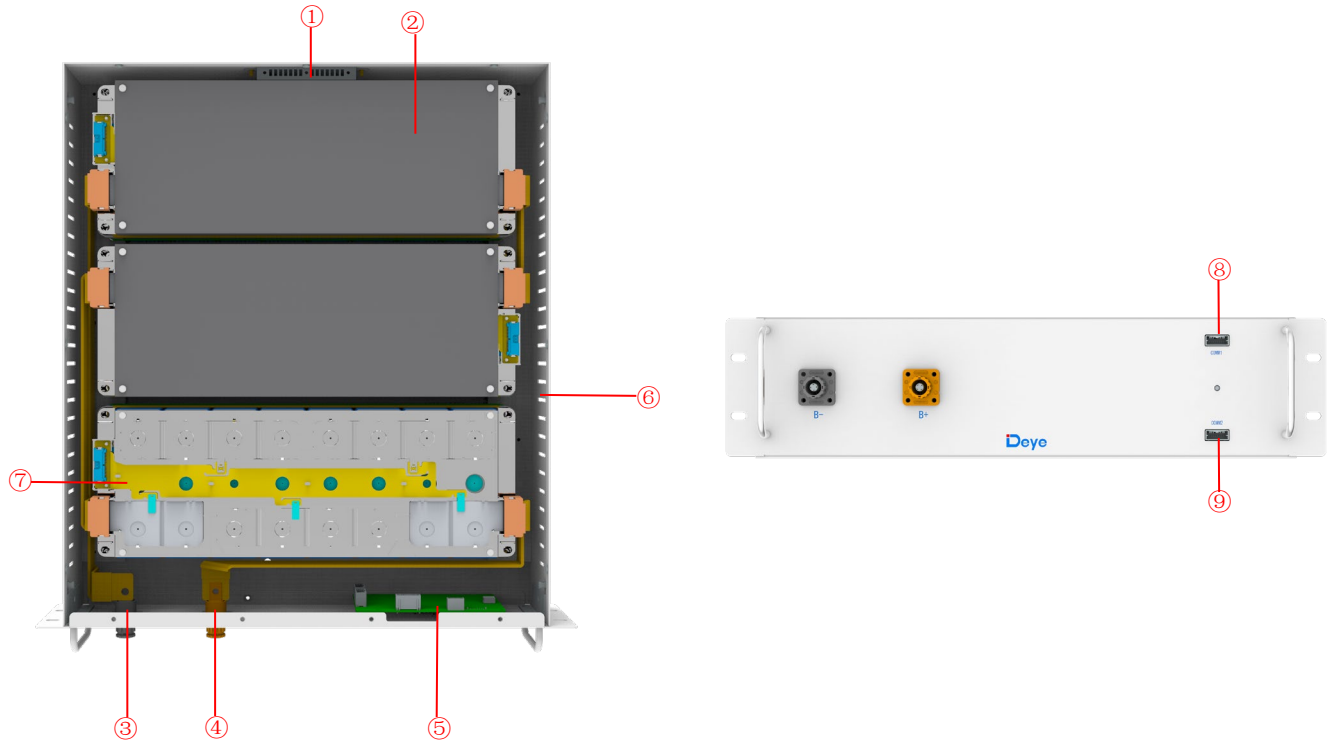

① Fire aerosol	Put out a fire
② Battery module	Provides electrical energy storage and output
③ Battery negative-	/
④ Battery positive+	/
⑤ BMU	Battery monitoring
⑥ Air inlet	Cold air inlet
⑦ CCS	Cells Contact System
⑧ COMM1	12VCD power supply port
⑨ COMM2	Communicative connection with the first battery module; and providing 12VDC power for the first battery module.

Typical application cases

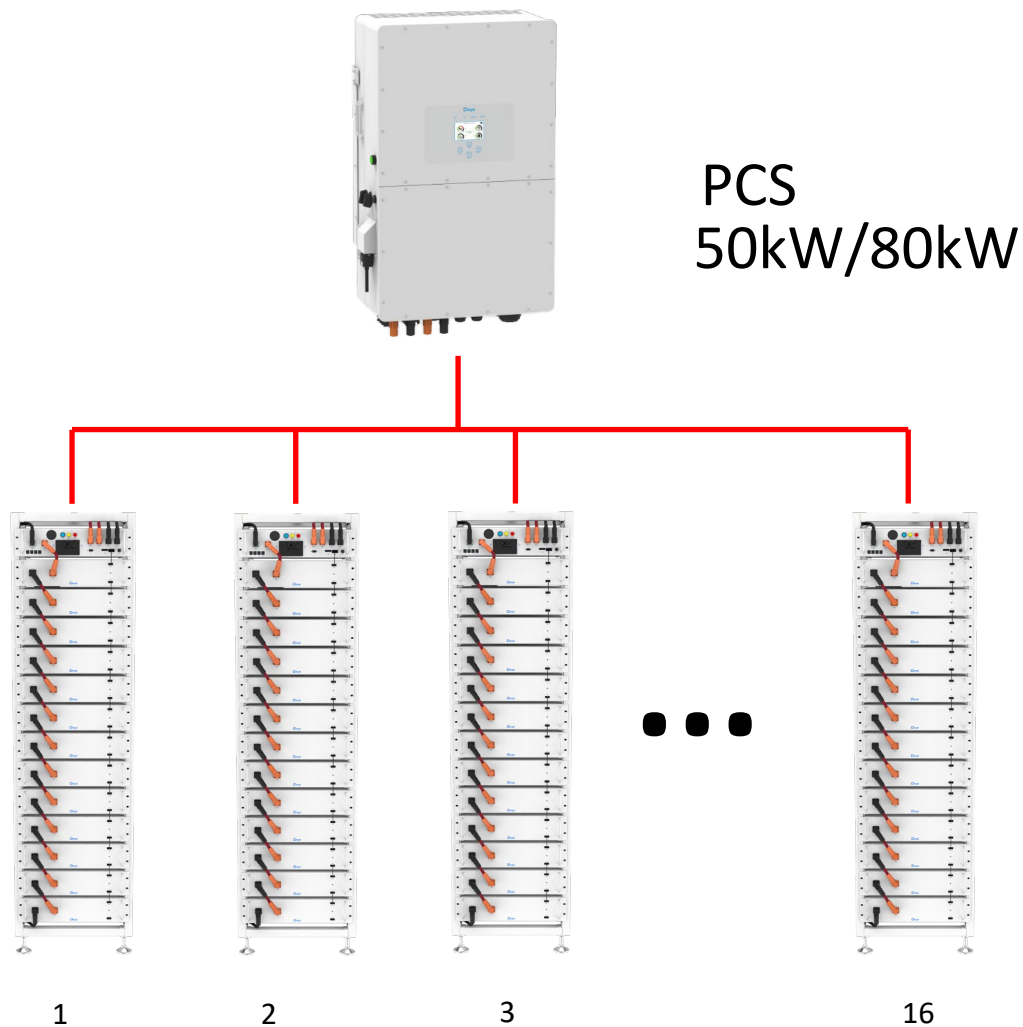

- An 50kW/80kW inverter can carry 1 to 16 high voltage boxes, PDU in parallel.
- A high voltage box can be equipped with 7 battery packs, 13 battery packs or 21 battery packs